

# Networks of Passive Oscillators

Vishwesh V. Kulkarni<sup>\*</sup>, Marc Riedel<sup>◇</sup>, Guy-Bart Stan<sup>†</sup>,

**Abstract**— We present new results on the synthesis of globally stable limit cycles in networks of passive oscillators. These passive oscillators can be represented as a modified *multi-input-multi-output* (MIMO) Lure’ system that is dissipative with respect to a certain supply rate. We use KS multipliers to establish the conditions under which the system undergoes either Hopf bifurcation or a pitchfork bifurcation. Under these conditions the network exhibits oscillations. Our results are applicable to networks of non-identical oscillators so long as the each oscillator is a passive oscillator.

**Index Terms**— oscillators, Hopf bifurcation, pitchfork bifurcation, global stability, Lure’ systems, Zames-Falb multipliers, KS multipliers

## I. INTRODUCTION

This paper is motivated by the problem of synthesizing controllers for networks of synthetic gene oscillators. Cell-signaling networks sense and encode dynamic information. Biochemical oscillators serve as timers of events in periodic processes (see [1], [2]) and, in particular, activation of signaling proteins can affect cell-fate decisions [3]. Therefore, the timing and amplitude of these pulses needs to be governed precisely [4]. Recently the p53-Mdm2 interaction has been modelled as a negative feedback system in [4] featuring nonlinearities which can be discerned as memoryless monotone nonlinearities. Such nonlinearities are also observed in the *Escherichia coli* based gene oscillator model derived in [5]. The problem of entraining oscillations and building arbitrarily large networks of synchronized (or phase-locked) oscillators has not been considered so far in synthetic biology even though synchrony across a population of cells has been well studied and literature on bacterial quorum sensing abounds (see [6], [7], [8], [9], and [10]). As is apparent from the ordinary differential equation (ODE) model derived in [4] and [5], these systems can be posed as interconnected Lure’ systems. In this paper, we establish relevant results for the relevant Lure’ system based oscillators.

Oscillators are dynamical systems that exhibit stable limit cycles. Recently, a dissipativity based framework to synthesize oscillators, and networks of synchronized oscillators, has been established in [11]. Following the dissipativity approach introduced in [12], sufficient conditions for the existence of limit cycles in a subclass of Lure’ systems have recently been derived in [11]; the systems of interest being the

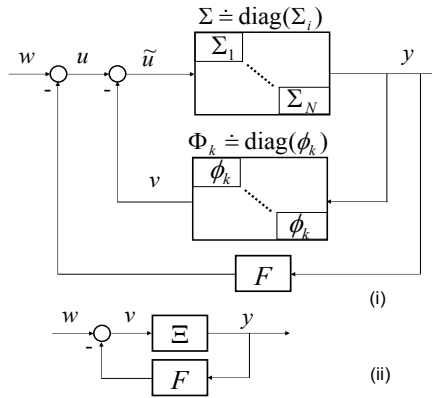

Fig. 1. (i): A modification of SISO Lure’ system to synthesize an oscillator —  $\Sigma$  is passive whereas  $\phi_k$  is related to a monotone memoryless positive nonlinearity  $\phi$  through the equation (2). (ii): A modification of MIMO Lure’ system to synthesize a network of identical oscillators —  $\Xi$  is passive whereas  $\Phi_k$  is the repeated diagonal nonlinearity with  $\phi_k$  as the repeating elements.

*single-input-single-output* (SISO) Lure’ systems and *multi-input-multi-output* (MIMO) Lure’ systems featuring repeated nonlinearities. In [11], an oscillator is viewed as an *open system*, i.e., as a dynamical system with an input  $u$  and an output  $y$ , and is characterized by a dissipation inequality between a storage and a supply; the storage reflects the energy stored in the internal system components whereas the supply rate governs the exchange of energy with the external world. An example of the supply rate  $w$ , as suggested for oscillators in [13], is the following:

$$w(u, y) = uy - d(y) + a_k(y), \quad a_k(y) \geq 0, \quad d(y) \geq 0. \quad (1)$$

Passivity with respect to the supply rate given by (1) describes a system that restores energy at low energy, that is,  $a_k(y) - d(y) > 0$  when  $|y|$  is small, and dissipates energy at high energy, that is,  $a_k(y) - d(y) < 0$  when  $|y|$  is large. One way to realize the dissipativity with a supply rate of the form (1) is through the feedback interconnection, shown in Fig 1(i), of a SISO passive system and a parametric static nonlinearity  $\phi_k$  defined by  $\phi_k(y) \doteq \phi(y) - ky$ , where  $k > 0$  and  $\phi$  is a positive monotone memoryless nonlinearity (see [11]). In this case, the supply rate  $w$  is given by  $w(u, y) = uy + ky^2 - y\phi(y)$ . The parameter  $k$  provides a bifurcation mechanism to create sustained oscillations in the feedback system [11]. A MIMO version of such systems is shown in Fig 1(ii), wherein the nonlinearity is repeated. In both cases, the limit cycle results from either supercritical Hopf

<sup>\*</sup> University of Minnesota, Department of Electrical and Computer Engineering, Minneapolis, MN 55455; Email: vkulkarn@umn.edu.

<sup>◇</sup> University of Minnesota, Department of Electrical and Computer Engineering, Minneapolis, MN 55455; Email: mriedel@umn.edu.

<sup>†</sup> Imperial College London, Department of Bioengineering and Centre for Synthetic Biology and Innovation, South Kensington Campus, SW7 2AZ, U.K.; Email: g.stan@imperial.ac.uk.

bifurcation, in which case the system is generalization of the Van der Pol oscillator, or from a slow adaptation added to a system exhibiting a supercritical pitchfork bifurcation, in which case the system is a generalization of the Fitzhugh-Nagumo oscillator (see [11]). We refer to such oscillators as *passive* oscillators since these oscillators are dissipative with respect to the supply rate defined by (1).

## II. PRELIMINARIES

Our notation mostly follows [14], [15], [16], and [17], and is summarized in Table 1; for the discrete time case, the integration terms are to be appropriately replaced by summation terms, and the discrete time counterpart of  $\mathcal{L}_2$  is referred to as  $\ell_2$ . The set of all  $N$ -dimensional real-valued vectors is denoted  $\mathbb{R}^N$ . We refer to an operator by using a capital letter symbol, such as  $H$ , whereas a signal is referred to by using a small letter symbol, such as  $x$ . Our short-hand notation for  $x(t) = 0 \forall t$  is  $x \equiv 0$ . A function  $f$  is said to be *smooth* if it is continuously differentiable in  $\mathbb{R}^n$  and twice continuously differentiable in a neighborhood of the origin. A function  $f$  is said to be a *Lyapunov function* for a given system  $\mathcal{S}$  if  $f$  is positive definite and if, in addition,  $\dot{f}$  is negative definite along the system trajectories. A function  $f$  is said to be *locally quadratic* if its Hessian evaluated at the origin is a positive definite symmetric matrix.

*Definition 1:* [finite-gain stability] A system  $\mathcal{S}$  mapping  $u \in \mathcal{L}_2$  into  $y \in \mathcal{L}_2$  is said to be *finite gain stable* if there exists  $\gamma \geq 0$  such that  $\|y\| \leq \gamma\|u\|$  for all  $u \in \mathcal{L}_2$ . The smallest value of such a  $\gamma$  is said to be the *gain* of  $\mathcal{S}$ .  $\square$

*Definition 2:* [sector] We say that  $H$  is a sector  $[k_1, k_2]$  operator if it holds that  $\langle Hx - k_1x, Hx - k_2x \rangle \leq 0$  for all  $x \in \mathcal{L}_2$ .  $\square$

*Definition 3:* [monotone nonlinearity] The class  $\mathcal{N}_M$  of monotone nonlinearities consists of all memoryless mappings  $N : \mathbb{R}^n \mapsto \mathbb{R}^n$  such that:

- 1)  $\langle N(x) - N(y), x - y \rangle \geq 0$  for all  $x, y \in \mathcal{L}_2$ ; and
- 2) there exists  $C \in \mathbb{R}^+$  s.t.  $\|N(x)\| \leq C\|x\| \quad \forall x \in \mathcal{L}_2$ .

The class  $\mathcal{N} \doteq \{N \in \mathcal{N}_M | N(0) = 0\}$  and the class  $\mathcal{N}_{odd} \doteq \{N \in \mathcal{N} | N(x) = -N(-x) \forall x\}$ .  $\square$

We next note down some notions from the passivity theory (see [12], [18], and [11]).

*Definition 4:* [passivity and dissipativity] Let  $x$  denote the state of a given system  $\Xi$ . Let  $u$  and  $y$  be, respectively, the input and the output of  $\Xi$ . Then,  $\Xi$  is said to be *dissipative* if there exists a scalar storage function  $\Omega(x) \geq 0$  and a scalar supply rate  $w(u, y)$  such that the dissipation inequality

$$\Omega(x(T^*)) - V(x(0)) \leq \int_0^{T^*} w(u(t), y(t)) dt \quad (2)$$

is satisfied for all  $T^* \geq 0$  for all state trajectories. If  $\Xi$  is dissipative with supply rate  $w(u, y) \doteq u^T y$ , it is said to be *passive*. If  $\Xi$  is dissipative with supply rate  $w(u, y) \doteq u^T y - d(y)$ , where  $d(y) > 0 \forall y \neq 0$ , it is said to be *strictly output passive*. If  $\Xi$  is dissipative with supply rate

TABLE I  
NOTATION

Symbol	Meaning
$(\mathbb{R}^+)$	Set of all (nonnegative) real numbers.
$\mathbb{Z}$	Set of all integers.
$(\cdot)'$ or $(\cdot)^T$	Transpose of a vector or a matrix $(\cdot)$ .
$\langle x, y \rangle$	$= \int_{-\infty}^{\infty} y^T(t)x(t)dt$
$\ x\ $	$= \sqrt{\langle x, x \rangle}$ .
$\mathcal{L}_2$	Space of possibly vector valued signals $x$ for which $\ x\  < \infty$ .
$\ z\ _1$	$= \int_{-\infty}^{\infty}  z(t)  dt$ .
$\hat{x}$	$= \int_{-\infty}^{\infty} x(t)e^{-j\omega t} dt$
$\delta(t)$	$= \begin{cases} 1 & \text{if } t = 0, \\ 0 & \text{else.} \end{cases}$
$\text{diag}(p_i)$	Diagonal matrix with $p_i$ as its diagonal elements.
$\text{Herm}(A)$	Hermitian of the given matrix $A$ .

$w(u, y) \doteq u^T y - e(u)$ , where  $e(u) > 0 \forall u \neq 0$ , it is said to be *strictly input passive*.  $\square$

*Remark 1:* If  $\Xi$  is linear time-invariant and detectable, its passivity is equivalent to the positive realness of its transfer function  $R(s)$  (see [18, Section 6.3]).  $\square$

*Definition 5:* [strong passivity] If  $\Xi$  is passive with a storage function which is a locally quadratic smooth Lyapunov function, it is said to be *strongly passive*.  $\square$

*Remark 2:* Detectable linear passive systems are strongly passive.  $\square$

## III. DETERMINATION OF BIFURCATIONS IN MODIFIED LURE' SYSTEMS

### A. System Description

The MIMO Lure' system of interest,  $\mathcal{S}_M$  shown in Fig. 1(ii), is defined by the following equations:

$$\Xi : \dot{x} = f(x) + g(x)v, \quad y = h(x), \quad (3)$$

$$v = -\Phi_k(y) + u, \quad (4)$$

where  $x, v, y \in \mathbb{R}^n$ , and the vector fields  $f(\cdot)$ ,  $g(\cdot)$ , and the function  $h(\cdot)$  are smooth.

We next describe the constraints on  $\Xi$  and  $\Phi_k$ . Let  $R_k(s)$  denote the transfer function of the linearization of  $\Xi_k$  at  $x = 0$ ; we assume that the origin  $x = 0$  is an equilibrium point of the *free* system, which corresponds to  $v = 0$ , i.e.,  $f(0) = 0$ . We also assume that  $h(0) = 0$  and  $g(0) \neq 0$ . Further, we assume that the pair  $(f, h)$  is zero-state detectable. In other words, we assume that every solution  $x$  of the free system  $\dot{x} = f(x)$  that yields  $y = h(x) \equiv 0$  converges to the zero solution asymptotically. The static nonlinearity  $\Phi_k(\cdot) = \text{diag}(\phi_k(\cdot))$  is a repeated nonlinearity, i.e.  $\Phi_k(y) = [\phi_k(y_1) \dots \phi_k(y_N)]^T$ , where  $\phi_k(y_i) \doteq \phi(y_i) - ky_i \forall i$  with  $y_i$  denoting the  $i$ -th element of  $y$ . The repeating nonlinearity  $\phi(\cdot)$  is smooth and belongs to the sector  $(0, \infty)$ . We stipulate  $\phi'(0) = 0$  so that the local slope of  $\phi_k(\cdot)$  is determined by  $k$ ; the parameter  $k$  thus regulates the level of *activation* of the nonlinearity near  $x = 0$ , and the sector condition

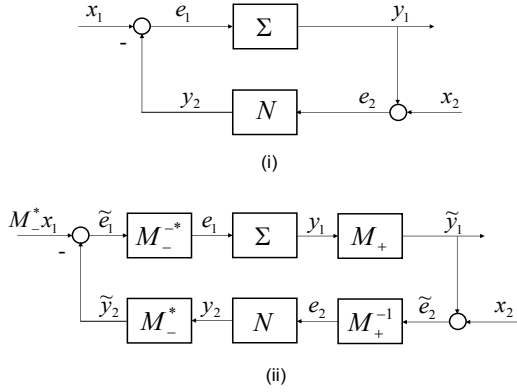

Fig. 2. (i): The feedback system  $\mathcal{S}_M$  —  $H(s)$  is a stable and linear time-invariant transfer function whereas  $N \in \mathcal{N}$ , the class of memoryless, incrementally positive, norm-bounded nonlinearities. (ii): An equivalent system obtained using multipliers. If the Zames-Falb multipliers are used, then  $M_+$ ,  $M_+^{-1}$ ,  $M_-^*$ ,  $M_-^{*-1}$  are causal and stable with finite gain.

then imposes  $\phi''(0) = 0$ . We refer to this system as  $\mathcal{S}_{MR}$ . If the diagonal terms in  $\Phi_k$  are not identical but otherwise satisfy the above properties, we refer to the feedback system as  $\mathcal{S}_M$ ; note that  $\mathcal{S}_{MR} \subset \mathcal{S}_M$ . In addition, we stipulate  $\phi'''(0) = \kappa > 0$  and  $\lim_{|s| \rightarrow \infty} \frac{\phi(s)}{s} = +\infty$ ; as per [19], this so-called *stiffening* nonlinearity condition is imposed to facilitate the global stability analysis via the following result.

*Lemma 1:*  $S_k(x)$  is a global Lyapunov function for  $\mathcal{S}_M$ .  $\square$

*Proof:* Note that  $\mathcal{S}_M$  with  $w \equiv 0$  is *absolutely stable* if it possesses a unique equilibrium  $x = 0$  which is globally asymptotically stable for any MIMO repeated nonlinearity  $\Phi(\cdot) = \text{diag}\{\phi(\cdot)\}$  with  $\phi(\cdot)$  in the sector  $(0, +\infty)$ . Since  $\Phi(y)$  is strictly input passive (see [18]),  $\mathcal{S}_M$  is absolutely stable if  $\Xi_k$  is strongly passive and zero-state detectable (see [18] and [20]). In that case, the storage function  $S_k(x)$  of  $\Xi_k$  satisfies the dissipation inequality  $\dot{S}_k \leq -y^T \Phi(y)$ . Hence,  $S_k(x)$  as a global Lyapunov function. QED.  $\blacksquare$

*Remark 3:* Global asymptotic stability of the equilibrium  $x = 0$  directly follows from the LaSalle invariance principle (see [20]). Since  $S_k(x)$  depends on  $k$ , the absolute stability of  $\mathcal{S}_M$  also depends on  $k$ . The effect of  $k$  on such stability analysis has been well discussed in [11].  $\square$

### B. Multiplier Theoretic Stability Analysis

We shall first illustrate the use of multiplier theory (see [16], [17], [21], and [22]) to reduce conservativeness in the stability analysis of the  $\mathcal{S}_M$ . Briefly speaking, the Zames-Falb multiplier approach to determining stability of a system rests on finding a class  $\mathcal{M}$  of possibly non-causal, linear-time-invariant multipliers that is *positivity preserving* for  $N$  in the sense that  $M \in \mathcal{M}$  implies positivity of the operator  $M^*N$ . Additionally, the multipliers  $M \in \mathcal{M}$  are required to be factorizable as  $M = M_- M_+$ , where  $M_-, M_+$  have the following properties: (i)  $M_-, M_+$  are invertible, and (ii)  $M_+, M_+^{-1}, M_-^*, M_-^{*-1}$  are causal and have finite gain. These

properties ensure that for any such multiplier, stability of the system shown in Figure 2(i) is equivalent to that of the system shown in Figure 2(ii). The following result, viz., [21, Theorem 2], on the stability of this system is well known.

*Theorem 1:* [21, Zames-Falb]

Suppose there is a mapping  $M$  (the multiplier) of  $\mathcal{L}_2$  into  $\mathcal{L}_2$  such that:

- 1) there are maps  $M_+$  and  $M_-$  of  $\mathcal{L}_2$  into  $\mathcal{L}_2$  with the following properties:
  - a)  $M = M_- M_+$ ;
  - b)  $M_-$  and  $M_+$  are invertible;
  - c)  $M_+, M_+^{-1}, M_-^*$  and  $M_-^{*-1}$  are causal and have finite gains  $\gamma(\cdot)$  (i.e. are bounded);
- 2)  $MH$  and  $M^*N$  are positive;
- 3) either  $MH$  is strongly positive and  $\gamma(H)$  is finite or  $M^*N$  is strongly positive and  $\gamma(N)$  is finite.

Then  $e_1, e_2 \in \mathcal{L}_2$ .  $\square$

Hence, the positivity preservation results are important in the stability of  $\mathcal{S}_M$ . A multiplier preserves positivity of a  $\mathcal{N}$  nonlinearity if and only if it is in  $\mathcal{M}^{ZF}$  (see [16] and [22]), which is defined as follows.

*Definition 6:* [Zames-Falb multipliers] The class  $\mathcal{M}^{ZF}$  of Zames-Falb multipliers comprises convolution operators, either continuous-time or discrete-time, such that the impulse response of an  $M \in \mathcal{M}^{ZF}$  is of the form

$$m(\cdot) = g \delta(\cdot) + h(\cdot) \quad \text{with} \quad h(\cdot) < 0 \quad \forall t, \quad \|h\|_1 < g,$$

where  $g, h(\cdot) \in \mathbb{R}$ .  $\square$

*Remark 4:* The Zames-Falb multiplier for a MIMO full-block  $\mathcal{N}$  nonlinearity is obtained by multiplying the scalar Zames-Falb multiplier, defined above, by an appropriate identity matrix.  $\square$

We now state [23, Theorem 1] on a set of sufficient conditions for the absolute stability of the unforced ( $w \equiv 0$ ) MIMO Lure feedback system represented in Figure 1(ii). We assume that the feedback interconnection is *ultimately bounded* which means that all solutions enter, in finite time, a compact and invariant set  $\Omega = \Omega(k)$  (see [18, Definition 5.1]).

*Theorem 2:* Consider  $\mathcal{S}_M$ . Let  $w \equiv 0$  and let  $k$  be fixed to a particular value. Let  $\Xi$  and its linearization be zero-state detectable, and let  $\phi \in \mathcal{N}_M$ . Furthermore, suppose the feedback interconnection of  $\Xi$  and  $\Phi_k(\cdot)$  is ultimately bounded. Then, the equilibrium  $x = 0$  is globally asymptotically stable if there exists an  $M \doteq M_-^* M_+ \in \mathcal{M}^{ZF}$  such that  $\tilde{\Xi}_k \doteq M_-^* \Xi_k M_+$  is strongly passive.  $\square$

*Proof:* The proof of Theorem 2 is given in [23] for the SISO case. The extension of this proof to the MIMO case is straightforward.  $\blacksquare$

### C. Determination of Bifurcations Using Multipliers

We now note down stability properties of  $\mathcal{S}_M$  as the parameter  $k$  increases from 0. We write  $k \gtrsim k^*$  to denote a value of the parameter  $k$  *slightly greater* than the critical bifurcation value  $k^*$ , i.e.  $k \in (k^*, \bar{k}]$  for some  $\bar{k} > k^*$ . Since  $\Xi$  is assumed to be strongly passive and zero-state detectable,

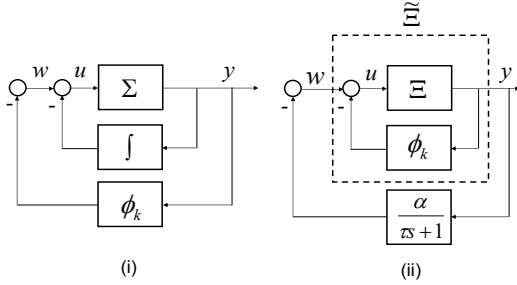

Fig. 3. (i): Oscillator using a Hopf bifurcation — passivity at the bifurcation point allows for a lossless exchange of energy between the two storage elements  $\Sigma$  and  $\frac{1}{s}$ . The static nonlinearity  $\phi_k$  regulates the dissipation in the feedback system, restoring energy when it is too low and dissipating it when it is too high. (ii): Oscillator using a pitchfork bifurcation — global bistability of the inner loop combined with a slow adaptation of the outer loop enables a feedback mechanism for relaxation oscillations characterized by a rapid switch between two *quasi-steady states*, i.e., states that would correspond to stable equilibria in the absence of the outer loop adaptation.

$\mathcal{S}_M$  with  $w \equiv 0$  is absolutely stable for  $k = 0$ . However, a bifurcation necessarily arises as the value of  $k$  is increased from 0; indeed, the linearization of this feedback system at  $x = 0$  possesses at least one eigenvalue in the right-half  $s$ -plane when  $k$  becomes large enough [24]. The result [11, Theorem 3] on the existence of bistability and bifurcation for this system is well known as follows.

**Theorem 3:** Consider the feedback system  $\mathcal{S}_M$  with  $w \equiv 0$ . Suppose  $\Xi$  and its linearization are zero-state detectable. Let  $k^* \geq 0$  be the smallest value of  $k$  at which the corresponding MIMO transfer function  $R_{k^*}(s)$  has a pole on the imaginary axis. Suppose there exists an  $M \doteq M_-^* M_+ \in \mathcal{M}^{ZF}$  such that  $\tilde{\Xi}_{k^*} \doteq M_-^* \Xi_{k^*} M_+$  is strongly passive. Then, the following results hold:

- 1) If  $R_{k^*}(s)$  has a unique pole on the imaginary axis, then the system has a supercritical pitchfork bifurcation such that, for  $k \gtrsim k^*$ , the system is globally bistable provided the feedback interconnection of  $\Xi$  and  $\Phi_k(\cdot)$  is ultimately bounded.
- 2) If  $R_{k^*}(s)$  has a unique pair of conjugated poles on the imaginary axis, then the system has a supercritical Hopf bifurcation such that, for  $k \gtrsim k^*$ , the system has a unique limit cycle which is globally asymptotically stable in  $\mathbb{R}^n \setminus E_s(0)$  provided the feedback interconnection of  $\Xi$  and  $\Phi_k(\cdot)$  is ultimately bounded,

where  $E_s(0)$  denotes the stable manifold of the unstable equilibrium  $x = 0$ .  $\square$

#### IV. LURE' SYSTEM BASED OSCILLATORS

Structure of the Lure' system based oscillators derived in [11] is shown in Fig. 3. Theorem 3 provides a high-dimensional generalization of the global bistability in the inner loop of Figure 3(ii). In order to convert the global

bistability result of Theorem 3 into a mechanism for global oscillations, we need only add a supervisory negative feedback loop through a stable first order filter as shown in Figure 3(ii) (see [11]). In particular, the following result on the synthesis of the Lure' system based oscillators is well known.

**Theorem 4:** [Stan-Sepulchre [11, Theorem 4]]

Under the assumptions of Theorem 3, suppose that the unforced feedback system  $\mathcal{S}_M$  undergoes a supercritical pitchfork bifurcation at  $k = k^*$ . Suppose this system is augmented by using the following supervisory feedback:

$$w_i = \begin{cases} -z & \text{if } i = i^*; \\ 0 & \text{else,} \end{cases}$$

where  $i^*$  is selected such that the linear center manifold dynamics are observable from  $y_i$ , and  $z$  is given by

$$\tau \dot{z} = -z + y_i,$$

for some  $\tau > 0$ . Suppose the augmented system is ultimately bounded. Then there exists a positive constant  $\bar{\epsilon}$  such that for any value of  $k$  in  $(k^*, k^* + \bar{\epsilon})$ , all solutions with initial conditions in  $\mathbb{R}^{n+1} \setminus E_s(0)$  converge to a unique asymptotically stable limit cycle if  $\tau \gg (k - k^*)^{-1}$ .  $\square$

**Remark 5:** If the forward system  $\Xi$  is linear, strongly passive and detectable, then ultimate boundedness is ensured since the adaptation dynamics  $\tau \dot{z} = -z + y_i$  are passive.  $\square$

**Definition 7:** [passive oscillators]

We say  $\mathcal{S}_M$  is a *passive oscillator* if it satisfies the following two conditions:

- 1)  $\mathcal{S}_M$  satisfies the dissipation inequality

$$\dot{S}_k \leq (k - k_{passive}^*) y^T y - y^T \Phi(y) + w^T y,$$

where  $S_k(x)$  is the storage function of  $\mathcal{S}_M$  the feedback system and  $k_{passive}^* \geq 0$  is the critical value of  $k$  above which it loses passivity.

- 2) In the absence of the forcing input  $w$ ,  $\mathcal{S}_M$  possesses a global limit cycle, i.e., a stable limit cycle that attracts all solutions except those belonging to the stable manifold of the origin.  $\square$

**Remark 6:** The first condition holds if  $\Xi$  is strongly passive. Theorems 3 and 4 provide sufficient conditions for the fulfillment of the second condition to be satisfied as well.  $\square$

#### V. INTERCONNECTED PASSIVE OSCILLATORS

The network of interconnected passive oscillators of interest to us comprises  $N$  SISO passive oscillators connected through possibly nonlinear coupling such that (see Fig. 4). The  $i$ -th oscillator has the critical value  $k_{i,passive}^*$ . Let  $\tilde{u}_i$  denote the input of the  $i$ -th oscillator and let  $y_i$  denote the output of the  $i$ -th oscillator. Suppose  $\tilde{u} = -\Phi_k(y) + u$ , where  $u \doteq w - \Gamma(y)$  and  $\Gamma$  is the interconnection matrix. Let us refer to this system as  $\mathcal{S}_{IN}$ . Since  $\Sigma_i$  is a passive oscillator, it satisfies the dissipation inequality

$$\dot{S}_{k,i} \leq (k_i - k_{i,passive}^*) y_i^2 - y_i \phi(y_i) + u_i y_i.$$



the kernel  $\bar{m}(t, \tau) \in \mathbb{R}^{p \times p}$  is the counterpart of  $\bar{m}_{k,l}$ . In the continuous time case,  $M$  is called a *time invariant operator* or, alternatively, a *convolution operator* if  $\bar{m}(t, \tau) = \bar{m}(t + \nu, \tau + \nu) \forall t, \tau, \nu \in \mathbb{R}$ . For a convolution operator  $M$ , a shorthand notation for  $\bar{m}(t, \tau)$  and  $\bar{m}_{i,j}$  is  $\bar{m}(t - \tau)$  and  $\bar{m}(i - j)$ , respectively with  $\bar{m}(t)$  and  $\bar{m}(k)$  denoting the respective *impulse response*.  $\square$

*Definition 11:* [hyperdominance, dominance]

An operator  $M : \ell_2 \rightarrow \ell_2$  is said to be *doubly dominant* if the elements  $m_{ij}$  of its associated matrix have the following properties.

$$m_{ii} \geq \sum_{j=-\infty, j \neq i}^{\infty} |m_{ij}|, \quad m_{ii} \geq \sum_{j=-\infty, j \neq i}^{\infty} |m_{ji}| \quad \forall i.$$

If, in addition, it also holds that  $m_{ij} \leq 0, \forall i \neq j$ , then  $M$  is said to be *doubly hyperdominant*. For an operator  $M : \mathcal{L}_2 \rightarrow \mathcal{L}_2$ , these notions are defined in terms of its kernel in an analogous manner with integrals suitably replacing sums.  $\square$

*Lemma 2:* [16, Willems]

Let  $M : \ell_2 \rightarrow \ell_2$  be a bounded linear operator. Then,  $\langle x, My \rangle$  is nonnegative for all similarly ordered unbiased (similarly ordered symmetric unbiased) sequences  $\{x\}, \{y\} \in \ell_2$  if and only if  $M$  is doubly hyperdominant (doubly dominant).  $\square$

*Definition 12:* [multipliers]

$\mathcal{M}_{odd}^{RS}$  denotes the class of MIMO convolution operators, either continuous or discrete, such that the impulse response of an  $M \in \mathcal{M}_{odd}^{RS}$  is of the form

$$m = g \delta - h,$$

where  $g, h(\cdot) \in \mathbb{R}^{p \times p}$  satisfy

$$g_{ii} \geq \sum_{i=1, i \neq j}^n |g_{ij}| + \sum_{i=1}^n \|h_{ij}\|_1 \quad \forall i = 1, 2, \dots, n,$$

$$g_{ii} \geq \sum_{j=1, j \neq i}^n |g_{ij}| + \sum_{j=1}^n \|h_{ij}\|_1 \quad \forall i = 1, 2, \dots, n.$$

By further stipulating  $g_{ij} \leq 0 \forall i \neq j, h_{ij}(\cdot) \geq 0 \forall i, j$ , the subclass  $\mathcal{M}^{RS}$  is obtained.  $\square$

*Theorem 6:* [25, Kulkarni-Safonov]

A bounded linear operator  $M$  mapping  $\ell_2^p$  into  $\ell_2^p$  [or  $\mathcal{L}_2$  into  $\mathcal{L}_2$ ] preserves positivity of every  $N \in \mathcal{N}^{RS}$  ( $N \in \mathcal{N}_{odd}^{RS}$ ) if and only if its associated matrix [kernel] is doubly hyperdominant (doubly dominant). Furthermore, a bounded convolution operator  $M$  mapping  $\mathcal{L}_2$  into  $\mathcal{L}_2$ , or mapping  $\ell_2^p$  into  $\ell_2^p$ , preserves positivity of every  $N \in \mathcal{N}^{RS}$  ( $N \in \mathcal{N}_{odd}^{RS}$ ) if and only if  $M \in \mathcal{M}^{RS}$  ( $M \in \mathcal{M}_{odd}^{RS}$ ).  $\square$

Now, our result on the equivalent of Theorem 2 for  $\mathcal{S}_{IN}$  is as follows.

*Theorem 7:* Consider the feedback system  $\mathcal{S}_{IN}$  of identical oscillators interconnected with linear coupling with  $w \equiv 0$ . Suppose  $\Xi$  and its linearization are zero-state detectable. Suppose there exists an  $M \doteq M_-^* M_+ \in \mathcal{M}^{RS}$  such that  $\tilde{\Xi}_{k^*} \doteq M_-^* \Xi_{k^*} M_+$  is strongly passive. Let  $k^* \geq 0$  be

the smallest value of  $k$  at which the corresponding MIMO transfer function  $R_{k^*}(s)$  has a pole on the imaginary axis. Then, the following results hold:

- 1) If  $R_{k^*}(s)$  has a unique pole on the imaginary axis, then the system has a supercritical pitchfork bifurcation such that, for  $k \gtrsim k^*$ , the system is globally bistable provided that the feedback interconnection of  $\Xi$  and  $\Phi_k(\cdot)$  is ultimately bounded.
- 2) If  $R_{k^*}(s)$  has a unique pair of conjugated poles on the imaginary axis, then the system has a supercritical Hopf bifurcation such that, for  $k \gtrsim k^*$ , the system has a unique limit cycle which is globally asymptotically stable in  $\mathbb{R}^n \setminus E_s(0)$  provided the feedback interconnection of  $\Xi$  and  $\Phi_k(\cdot)$  is ultimately bounded,

where  $E_s(0)$  denotes the stable manifold of the unstable equilibrium  $x = 0$ .  $\square$

*Theorem 8:* Consider the feedback system  $\mathcal{S}_{IN}$  of possibly non-identical oscillators interconnected with possibly nonlinear coupling with  $w \equiv 0$ . Suppose  $\Xi$  and its linearization are zero-state detectable. Suppose there exists an  $M \doteq M_-^* M_+ \in \mathcal{M}^{RS}$  such that  $\tilde{\Xi}_{k^*} \doteq M_-^* \Xi_{k^*} M_+$  is strongly passive. Let  $K = \text{diag}(k_i)$ , where  $k_i > 0$ , be the diagonal matrix of the smallest shifts needed such that  $\tilde{\Gamma} \doteq \Gamma + K \geq 0$  and  $\text{rank}(\tilde{\Gamma}) = N - 1$ . Furthermore, suppose it holds for a  $k_i$  that  $\text{rank}((1 - K\Sigma)\Sigma^{-1} + \Gamma) = N - 1$ . Then, the following results hold:

- 1) If the linearization of  $\Xi$  at  $k = k^*$  has a unique pole on the imaginary axis, then a subset of the system has a supercritical pitchfork bifurcation such that, for  $k \gtrsim k^*$ , a subset of the system is globally bistable provided the feedback interconnection of  $M\Xi$  and  $\Phi_k(\cdot)$  is ultimately bounded.
- 2) If the linearization of  $\Xi$  at  $k = k^*$  has a unique pair of complex conjugate poles on the imaginary axis, then a subset of the system has a supercritical Hopf bifurcation such that, for  $k \gtrsim k^*$ , it has a unique limit cycle which is globally asymptotically stable in  $\mathbb{R}^n \setminus E_s(0)$  provided the feedback interconnection of  $M\Xi$  and  $\Phi_k(\cdot)$  is ultimately bounded.

where  $E_s(0)$  denotes the stable manifold of the unstable equilibrium  $x = 0$ .  $\square$

## VI. CONCLUSION

We have presented new results on the synthesis of globally stable limit cycles in the networks of passive oscillators. These limit cycles are realized by making use of either Hopf bifurcation or pitchfork bifurcation. The network of interest is a modified Lure' system that is decomposable as an interconnection of a passive system and a repeated monotone nonlinearity. We have built on the results derived in [24] for identical passive oscillators by making use of the KS multipliers derived in [25] for repeated monotone nonlinearities. Specifically, given a network of passive oscillators, we establish the conditions under which either all oscillators or a subset of those will exhibit globally stable limit cycles.

## VII. ACKNOWLEDGMENT

This work is supported, in parts, by NSF CAREER Award 0845650.

## REFERENCES

- [1] J. Mitchison, *The Biology of Cell Cycle*. Cambridge, U.K.: Cambridge University Press, 1971.
- [2] J. Dunlap, J. Loros, and P. Decoursey, *Chronobiology: Biological Timekeeping*. Sunderland: Sinauer Associates, 2004.
- [3] S. D. Santos, P. J. Verveer, and P. I. Bastiaens, "Growth factor-induced MAPK network topology shapes Erk response determining PC-12 cell fate," *Nature Cell Biology*, vol. 9, pp. 324–330, 2007.
- [4] J. E. Toettcher, C. Mock, E. Batchelor, A. Loewer, and G. Lahav, "A synthetic-natural hybrid oscillator in human cells," *PNAS*, vol. 107, pp. 17047–52, September 2010.
- [5] J. Stricker, S. Cookson, M. Bennet, W. Mather, L. Tsimring, and J. Hasty, "A fast robust tunable synthetic oscillator," *Nature*, vol. 456, pp. 516–520, November 2008.
- [6] R. Vicente, L. Gollo, C. Mirasso, I. Fischer, and G. Pipa, "Dynamic relaying can yield zero time lag neuronal synchrony despite long conduction delays," *PNAS*, vol. 105, pp. 17157–17162, November 2008.
- [7] A. Winfree, *The Geometry of Biological Time*. Springer Verlag, 2000.
- [8] A. Goldbeter, *Biochemical Oscillations and Cellular Rhythms*. Cambridge, U.K.: Cambridge University Press, 1996.
- [9] T. Danino, O. Mondrago-Palomino, L. Tsimring, and J. Hasty, "A synchronized quorum of genetic clocks," *Nature*, vol. 463, no. 7279, pp. 326–330, 2010.
- [10] S. Strogatz, *Nonlinear Dynamics and Chaos: With Applications to Physics, Biology, Chemistry, and Engineering*. Cambridge, MA: Preseus Book, 1994.
- [11] G. Bart-Stan and R. Sepulchre, "Analysis of interconnected oscillators by dissipativity theory," *IEEE Transactions on Automatic Control*, vol. 52, pp. 256–270, February 2007.
- [12] J. Willems, "Dissipative dynamical systems," *Archives of Rational Mechanics and Analysis*, vol. 45, pp. 321–393, 1972.
- [13] L. Chua, "Passivity and complexity," *IEEE Transactions on Circuits and Systems I*, vol. 46, pp. 71–82, January 1999.
- [14] S. Sastry, *Nonlinear Systems - Analysis, Stability and Control*. New York, New York: Springer Verlag, 1999.
- [15] C. Desoer and M. Vidyasagar, *Feedback Systems: Input-Output Properties*. New York, New York: Academic Press, 1975.
- [16] J. Willems, *The Analysis of Feedback Systems*. Cambridge, MA: The MIT Press, 1971.
- [17] A. Megretski and A. Rantzer, "System analysis via integral quadratic constraints," *IEEE Transactions on Automatic Control*, vol. 42, pp. 819–830, June 1997.
- [18] H. K. Khalil, *Nonlinear Systems*. New York, New York: Macmillan, 1992.
- [19] M. Arcak and A. Teel, "Input-to-state stability for a class of Lure' systems," *Automatica*, vol. 38, pp. 1945–1949, November 2002.
- [20] R. Sepulchre, M. Jankovic, and P. Kokotovic, *Constructive Nonlinear Control*. London, U. K.: Springer Verlag, 1997.
- [21] G. Zames and P. Falb, "Stability conditions for systems with monotone and slope-restricted nonlinearities," *SIAM J. Control and Optimization*, vol. 6, pp. 89–108, 1968.
- [22] M. Safonov and V. Kulkarni, "Zames-Falb multipliers for MIMO nonlinearities," *International Journal of Robust and Nonlinear Control*, vol. 10, no. 11/12, pp. 1025–1038, 2000.
- [23] R. Sepulchre and G. Bart-Stan, "Feedback mechanisms for global oscillations in Lure systems," *System and Control Letters*, vol. 54, pp. 809–818, February 2005.
- [24] G. Stan, *Global Analysis and Synthesis of Oscillations: A Dissipativity Approach*. PhD thesis, University of Liege, March, 2005.
- [25] V. V. Kulkarni and M. G. Safonov, "All multipliers for repeated monotone nonlinearities," *IEEE Transactions on Automatic Control*, vol. 47, pp. 413–416, July 2002.
- [26] N. Geva-Zatorsky, N. Rosenfeld, S. Itzkovitch, R. Milo, A. Sigal, E. Dekel, T. Yarnitzky, Y. Liron, P. Polak, G. Lahav, and U. Alon, "Oscillations and variability in the p53 system," *Molecular System Biology*, vol. 2:2006.0033, 2006.